

SK 60 TV 1665

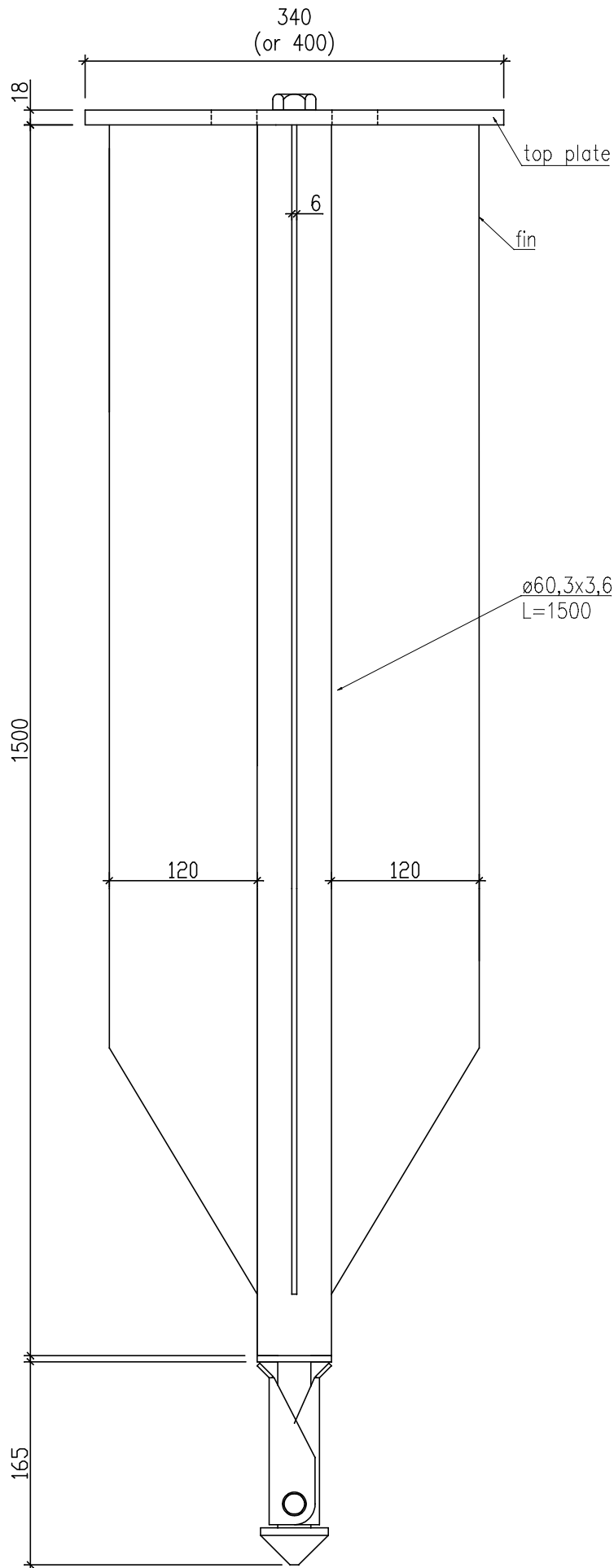

A-A

Solution with shovel
SCALE 1:5

GP 60 TV 1500

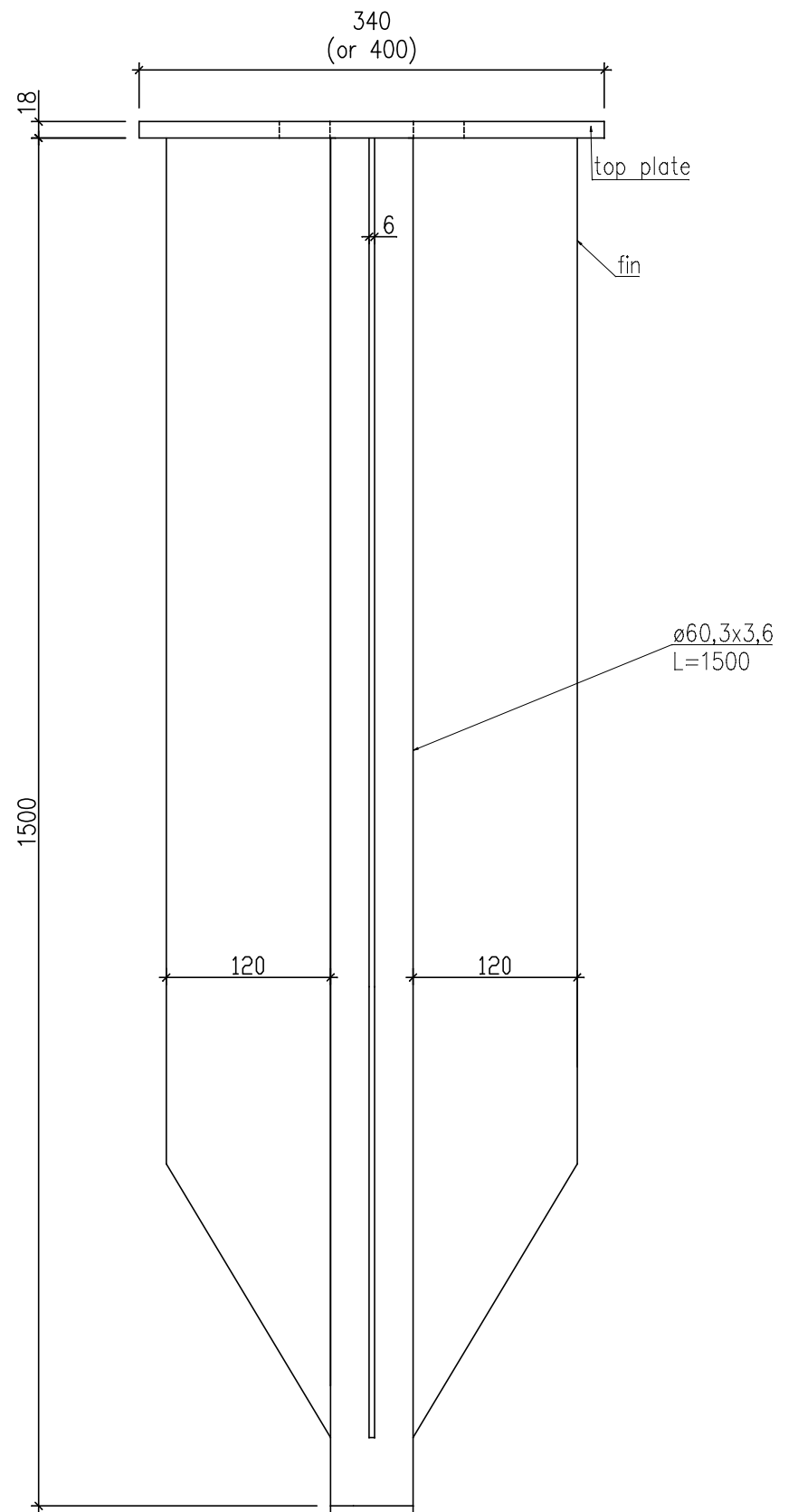

A-A

Solution without shovel
SCALE 1:5

REMARKS:

1. Dimensions of holes for bolts based on contracting body need.
2. Distance between holes based on contracting body need.
3. Size of bolts/threaded rods based on contracting body need.
4. Recommended bolts/threaded rods are: M20 cl.8.8.
5. Cl.8.8 can be changed to A4-80 upon request.
6. Main grade of the steel is s355. It can be changed to s235 upon request.

CONFIDENTIAL

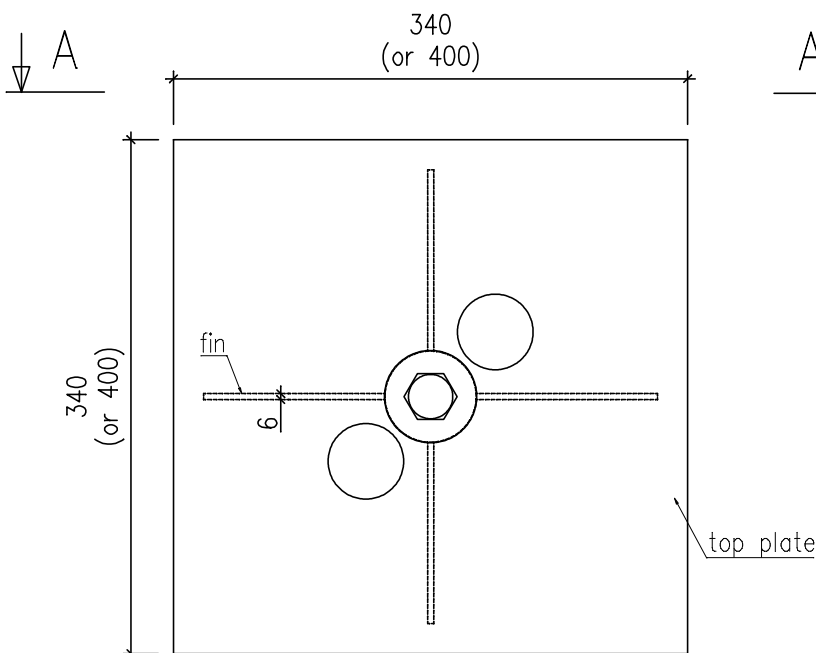

GROUND PLUG™

Finish Acc. to EN ISO 1461		Material/Steel grade S355		Sub-grade -		Tolerances acc. to: PN-EN ISO 9013:2008 PN-EN ISO 13920:2000	
Design	www.groundplug.com	Signature	2015-03-18	Scale 1:5;1:2		Change/Date 2015-03-18	Sheet
Draw	www.groundplug.com		2015-03-18	Format A3			
Check	Name	Signature	Date	Version v1			
Confirm				File name sales drawing		Projection	
Product GP60TV1500/SK60TV1665			Top plate 340x340 400x400		Number of drawing GroundPlug		
Object name GP60TV1500/SK60TV1665							