

SK 76 TV 2165

GP 76 TV 2000

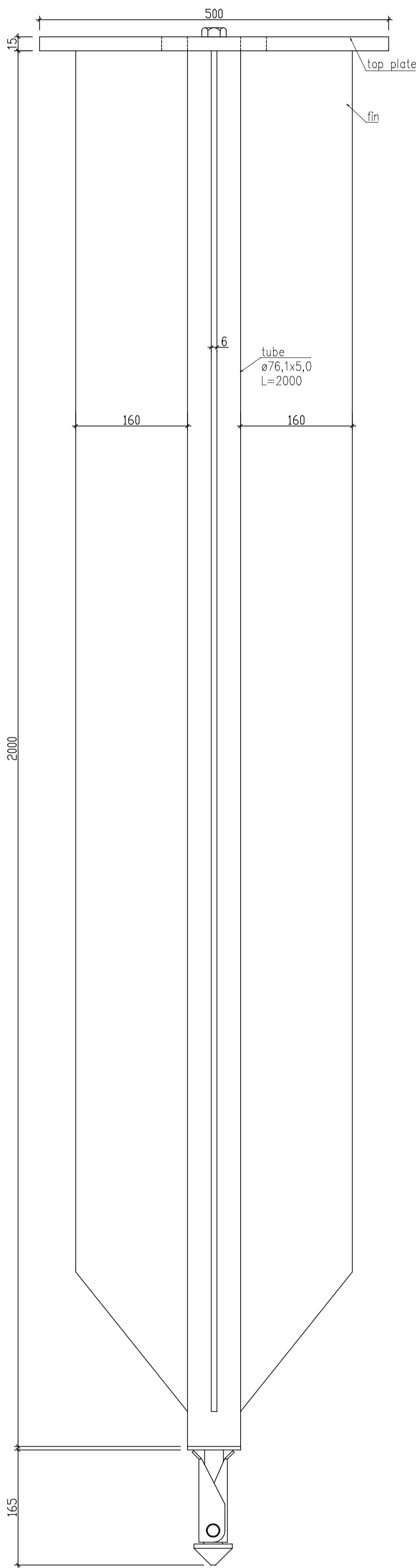

A-A
Solution with shovel
SCALE 1:5

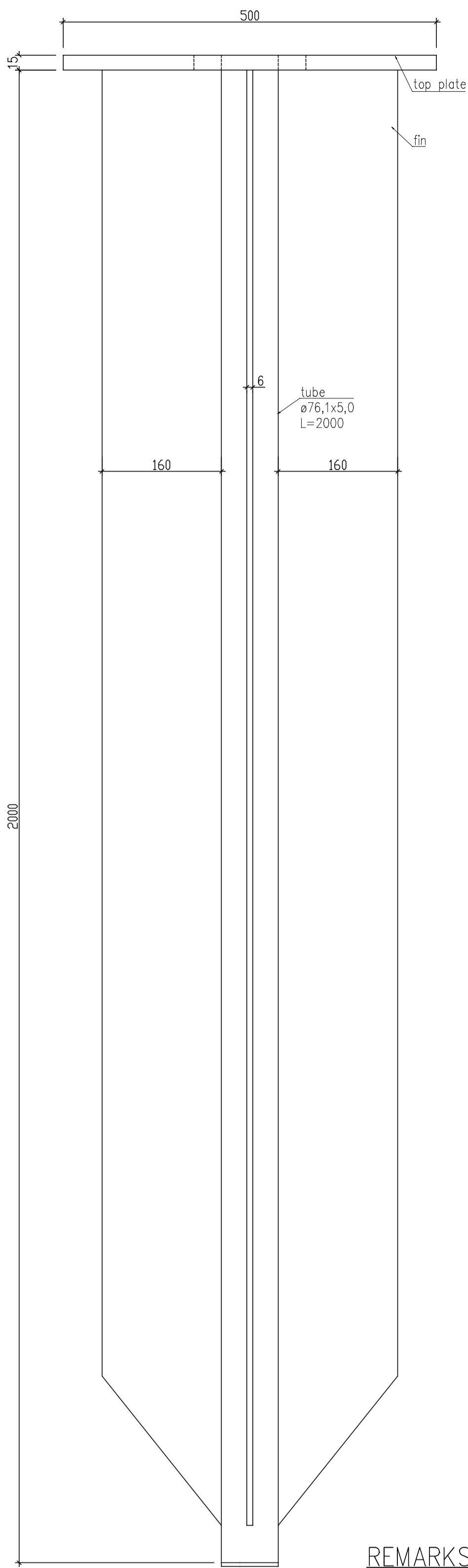

A-A
Solution without shovel
SCALE 1:5

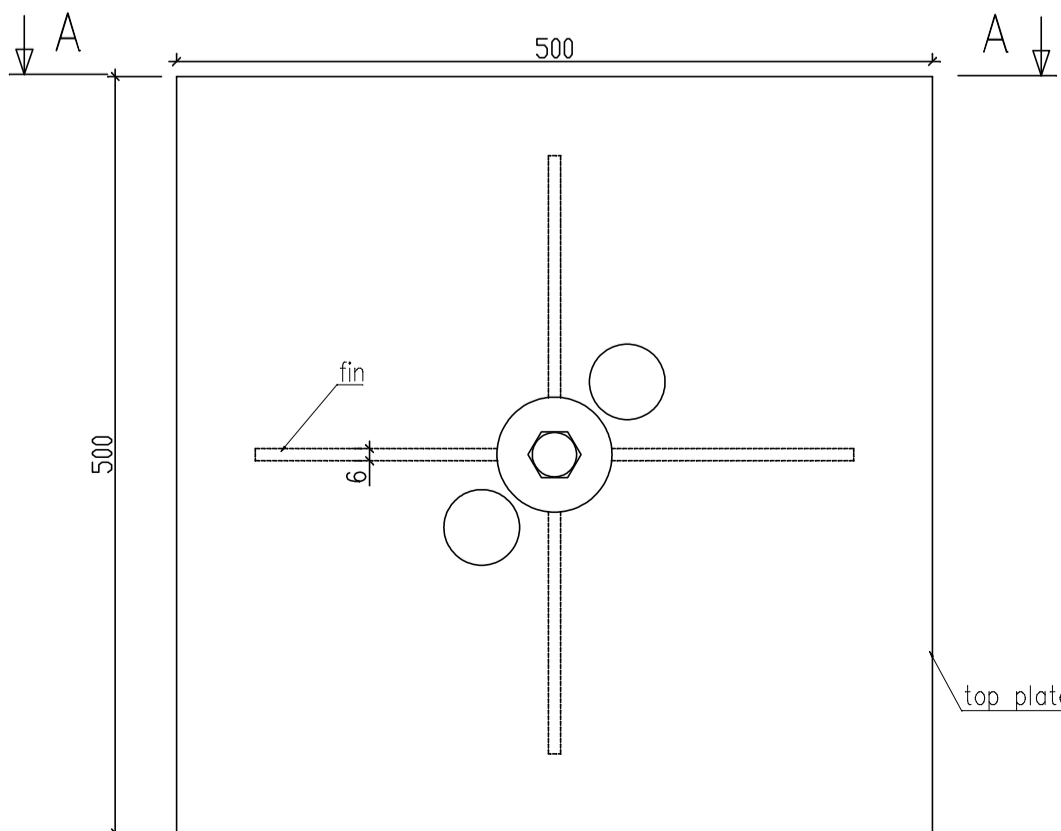

REMARKS:

1. Dimensions of holes for bolts based on contracting body need.
2. Distance between holes based on contracting body need.
3. Size of bolts/threaded rods based on contracting body need.
4. Recommended bolts/threaded rods are: M24 cl.8.8.
5. Cl.8.8 can be changed to A4-80 upon request.
6. Main grade of the steel is s355. It can be changed to s235 upon request.

CONFIDENTIAL

GROUND PLUG™

Finish	Acc. to EN ISO 1461	Material/Steel grade	S355	Sub-grade	-	Tolerances acc. to:	PN-EN ISO 9013:2008 PN-EN ISO 13920:2000
Design	www.groundplug.com	Date	2015-03-18	Scale	1:5;1:2		
Draw	www.groundplug.com	Date	2015-03-18	Format	A2	Version	v1
Check		Signature		Change/Date	2015-03-18		
Confirm		Signature					
Product	GP76TV2000/SK76TV2165	Top plate	500x500	File name	sales drawing	Sheet	
Object name	GP76TV2000/SK76TV2165			Number of drawing	GroundPlug	Projection	⊕