

SK 76 TV 2665

GP 76 TV 2500

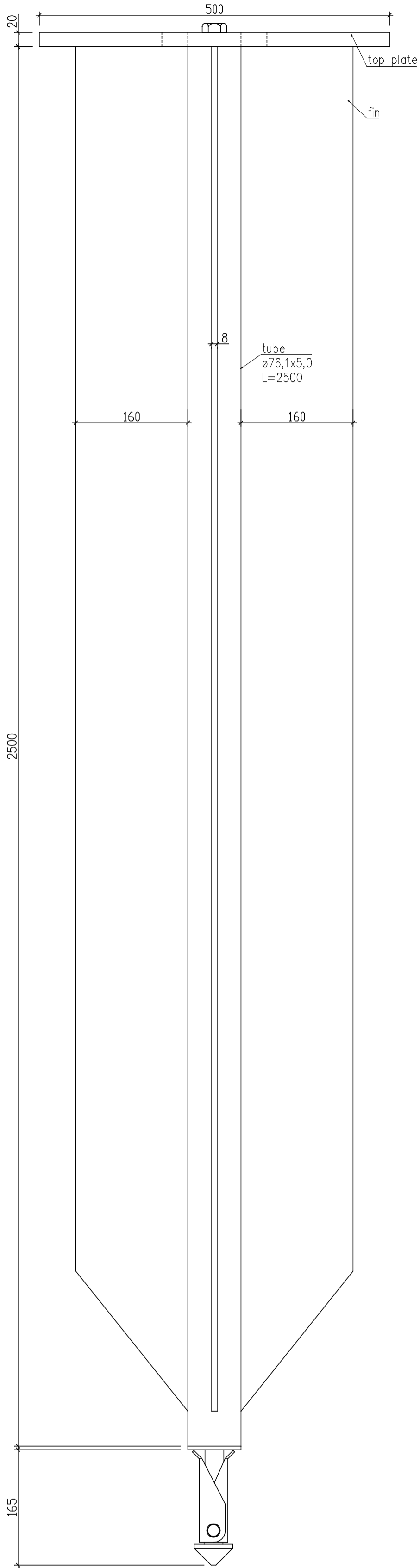

A-A
Solution with shovel
SCALE 1:5

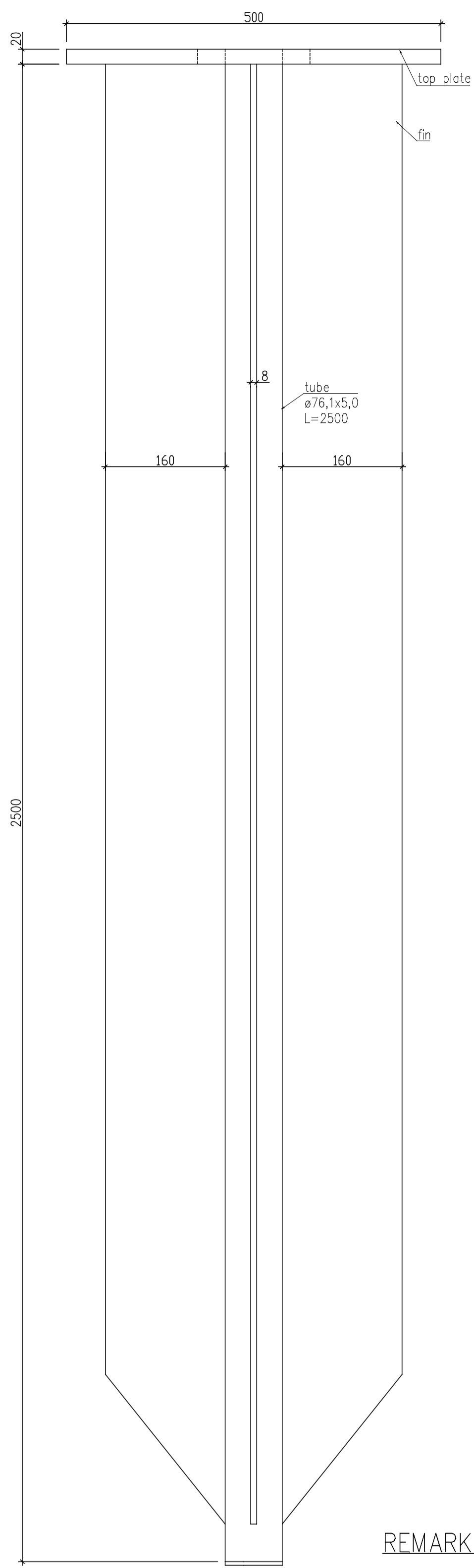

A-A
Solution without shovel
SCALE 1:5

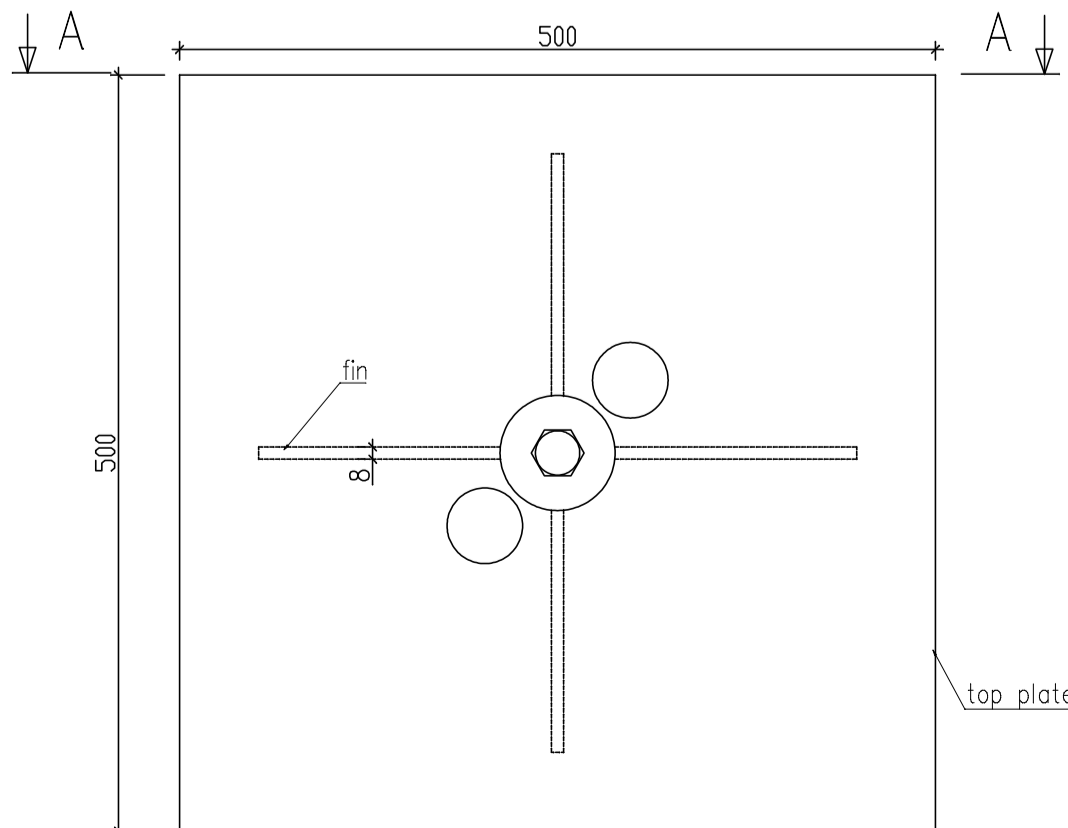

REMARKS:

1. Dimensions of holes for bolts based on contracting body need.
2. Distance between holes based on contracting body need.
3. Size of bolts/threaded rods based on contracting body need.
4. Recommended bolts/threaded rods are: M24 cl.8.8.
5. C1.8.8 can be changed to A4-80 upon request.
6. Main grade of the steel is s355. It can be changed to s235 upon request.

CONFIDENTIAL

GROUND PLUG™

Finish Acc. to EN ISO 1461	Material/Steel grade S355	Sub-grade -	Tolerances acc. to: PN-EN ISO 9013:2008 PN-EN ISO 13920:2000
Design www.groundplug.com	2015-03-18	Scale 1:5;1:2	
Draw www.groundplug.com	Date 2015-03-18	Format A2	Version v1
Check	Signature	Change/Date 2015-03-18	
Confirm			
Product GP76TV2500/SK76TV2665	Top plate 500x500	File name sales drawing	Sheet
Object name GP76TV2500/SK76TV2665		Number of drawing GroundPlug	Projection